

# Cryogenic Temperature Monitor

## Model 18

### Eight input channels with Ethernet connectivity

The Model 18 is the most compact and flexible eight channel cryogenic temperature monitor on the market. Virtually any cryogenic temperature sensor from any manufacturer can be selected by a single setting of the front panel. Additionally, custom or specially calibrated sensors require only a simple setup procedure. Unique features include: Low cost per channel, Internal Data Logging, Ethernet connectivity, a large easy to read display and extensive utility software.

Ethernet connectivity adds a new dimension of utility in both industrial and laboratory applications. Ethernet is more reliable and easier to use compared to other communication standards. Furthermore, it is essential to remote, distributed sensor or Local Area Network based systems.

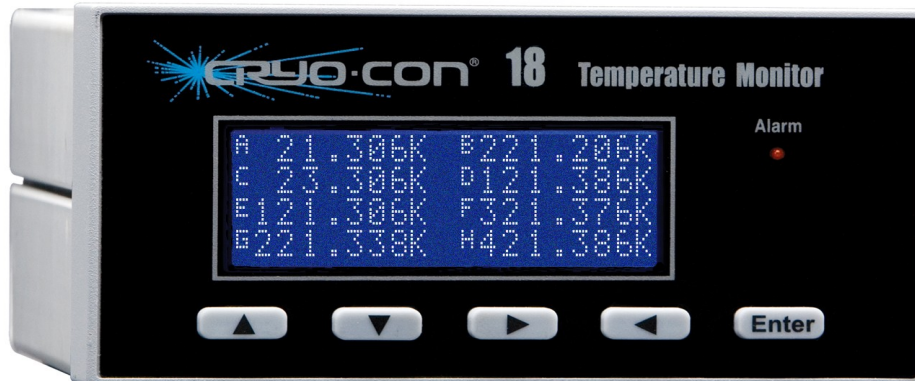

- Eight input channels that can be independently configured to support Diode, Platinum RTD and many cryogenic NTC temperature sensors.
- Operation from 1.4 to 500K with any Silicon Diode sensor, 14K to 1020K with Platinum RTDs and 2.0K to 200K with Ruthenium-Oxide sensors.
- Continuous data logging into internal Non-Volatile memory.
- High speed Ethernet LAN interface, Electrically isolated.
- Built-in web server. Temperature monitoring and instrument configuration can be performed using any web browser.
- Ethernet TCP/IP for complete remote control using a simple IEEE-488.2 like ASCII command language.
- SMTP interface sends e-mail on a selected alarm condition.
- LabView drivers available for the Ethernet TCP/IP port.



**Flexibility:** The Model 18 has eight independent and identical multi-purpose sensor inputs. Each can be easily configured to support virtually any cryogenic temperature sensor. Configuration is performed from the instrument's front panel or a remote interface. There are no jumpers, trim pots or switches.

**Silicon Diode** sensors from Cryo-con or any other manufacturer are directly supported over their full 1.4 to 500K range using built-in calibration curves and sensor data. Plus, non-volatile Flash memory is available for several custom or calibrated sensors.

**Platinum RTD** sensors can use built-in DIN 43760 (IEC 750) standard setups for 100Ω or 1,000Ω devices. The Model 18 uses the DIN standard for temperatures from 70K to 1020K and extends it for cryogenic use. Operation down to 14K is possible with user supplied curves.

A unique feature is the use of a ratiometric resistance bridge technique to measure Platinum RTD sensors. This significantly reduces low frequency noise and drift to provide rock-solid measurements.

Negative Temperature Coefficient (NTC) sensors commonly used in cryogenic applications include **Ruthenium-oxide**, **Cernox™**, **Carbon-Glass™**, **Germanium** and several others. These sensors are supported by using a 10μA constant-current DC excitation.

Model 18 Supported Sensors		
	Temperature Range	Example Sensors
<b>Diode</b>	1.4 - 500K	Cryo-con S900, S800. SI-440, 430, 410. Lakeshore DT-670, 470
<b>Platinum RTD</b>	14 - 1200K	Cryo-con CP-100 Cryo-con GP-100 Cryo-con XP-100 Cryo-con XP-1K
<b>Rhodium-Iron</b>	1.4 - 800K	Oxford PHZ 0002
<b>Cernox™</b>	1.5K - 325K	Lakeshore, all types
<b>Carbon-Ceramic</b>	4.2K - 300K	TMi-A1
<b>Ruthenium Oxide</b>	1.5K - 200K	Cryo-con R400

**Accuracy:** Measurement accuracy is obtained by using a 24-bit analog to digital conversion. Accuracy is further enhanced by extensive use of Digital Signal Processing (DSP) techniques.

The Model 18 includes built-in curves that support most industry standard temperature sensors. Additionally, eight **user calibration curves** are available for custom or calibrated sensors. Each curve may have up to 200 entries.

The accuracy of any sensor can be greatly improved by the use of Cryo-con's **CalGen®** feature. This will fit a Diode, Platinum RTD or NTC resistor sensor's calibration curve at up to three user specified temperature points. It is a built-in, easy to use method for obtaining higher accuracy temperature measurements without expensive sensor calibrations.

**Lowest Noise:** The Model 18 was designed for use in extremely low noise environments that cryogenic systems often require. Linear-mode power supplies are used and sensor excitation current sources are not multiplexed.

The enclosure is all Aluminum with wide conductive overlaps on all mating metal surfaces so that radiated RFI noise is virtually eliminated. An effective shielding and grounding scheme further allows the user to minimize both conducted and radiated noise.

**Easy to use:** The Model 18 front panel consists of a large, bright Vacuum Fluorescent display and a 5-key keypad. Most features and functions can be accessed via this simple and intuitive menu driven interface.

All eight temperature readings are displayed in a 2 x 4 matrix.

Temperature displays are autoranged to show the most number of significant digits. Built-in digital filters can be used to smooth temperature data. Displays are in units of K, °C, °F, Volts or Ohms.

The status of built-in alarms are indicated by an LED located to the right of the display.

Complex operations such as installing a new sensor require a remote interface connection.

**Data logging** is performed by continuously recording temperature and status to an internal 20K byte circular memory buffer. Data is time stamped so that the actual time of an event can be determined. Non-volatile memory is used so that data will survive a power failure. The Model 18 will log 1,000 samples. Each sample includes readings for all eight channels.

**Ethernet:** The Model 18 connects directly to any **10/100 Base-T Ethernet** Local-Area-Network or directly to any PC. Simple connection to any existing Local Area Network allows stable, precise, cost-effective measurements in laboratory or industrial environments as well as in remote, distributed data acquisition systems. The Model 18 can even be connected directly to the Internet with a user-supplied IP address.

Using the Ethernet **HTTP** protocol, the monitor's **embedded web server** allows the instrument to be viewed and configured from any web browser. An example 'Status' page is shown below.

Input channels can be configured using text entry and drop-down box selections by going to the monitor's 'Inputs' web page.

Using the **SMTP** protocol, the monitor will send e-mail based on selected alarm conditions. E-mail is completely configured by using the web page interface.

The **TCP/IP data port server** brings fast Ethernet connectivity to all common data acquisition software programs including LabView™.

TCP/IP protocol is used to implement a text based command language like those commonly used with IEEE-488 or RS-232 interfaces. This is the primary way that user software interfaces to the monitor.

The remote command language is SCPI compliant according to the IEEE specification.

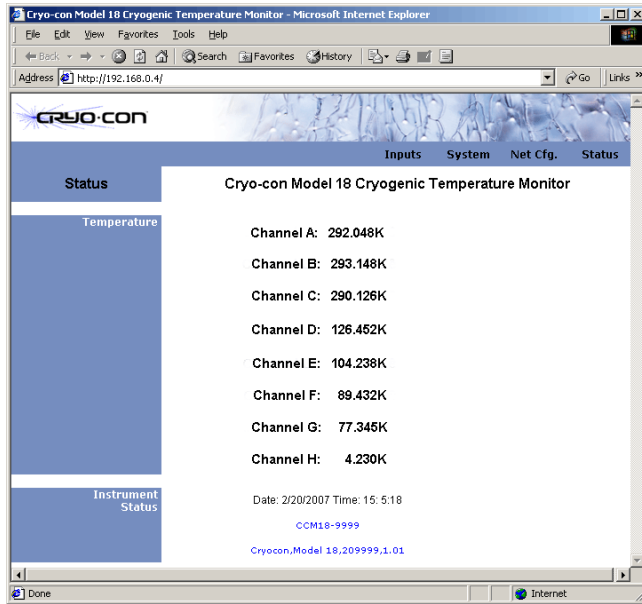

With Ethernet connectivity, the user has complete control of the monitor by using any web-enabled device from desktop PC to a wireless Pocket PC™. It is platform and operating system independent, working equally well with Windows, Linux or Macintosh based computers. There are no expensive cards or cables and, best of all, no confusing configuration requirements.

**Supplied Software:** Utility software is provided that connects any Windows based personal computer to the monitor. This software provides a graphical control panel that greatly simplifies instrument setup and configuration.

Sensor calibration curves may be downloaded to the monitor, viewed and edited. Most file formats are directly supported and can be easily converted to Cryo-con's® standard format.

The CalGen™ function allows the user to fit an existing sensor calibration curve to one- two- or three user-specified points. The result is a high accuracy sensor calibration at low cost.

PC based eZNET libraries are provided that allow easy Ethernet connection to most programming languages including Basic and C++.

**LabView:** LabView™ drivers are provided for the Ethernet TCP/IP interface.

## Ordering Information

Part Number	Description
<b>Model 18-110</b>	Eight-channel monitor set for 90 to 120VAC with USA power cord.
<b>Model 18-220</b>	Eight-channel monitor set for 200 to 240VAC with universal Euro cord.

## Rear panel connections

- Input Connectors: Four DB-9 recepticals provide 4-wire measurement connection to two sensors each.
- LAN: Standard RJ-45 Ethernet connector with built-in connection and activity LEDs.
- AC Power: RFI filtered Power Entry Module including AC power line switch and fuse drawer. Line voltage selection is performed by internal jumpers.

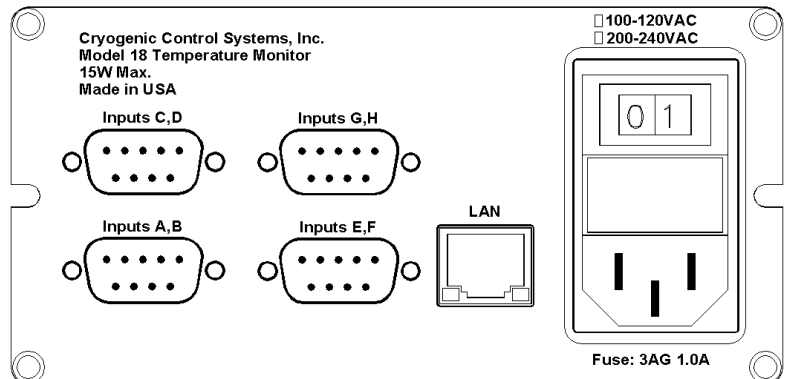

# Specifications

## User Interface

**Display Type:** Graphics VFD, 4mm character height.  
**Number of Inputs Displayed:** Eight.  
**Keypad:** Sealed Silicon Rubber.  
**Temperature Display:** Six significant digits, autoranged.  
**Display Update Rate:** 0.5 Seconds.  
**Display Units:** K, C, F or native sensor units.  
**Display Resolution:** Up to seven significant digits.

## Input Channels

There are eight identical input channels, each may be independently configured for any of the supported sensor types.

**Sensor Connection:** 4-wire differential. DB-9 receptacle.  
**Sensor Types:** See supported sensors table.  
**Sensor Selection:** Front Panel or remote interface.  
**Sensor Excitation:** DC constant-current: 1mA, 100µA or 10µA.  
**Resistance Measurement type:** Ratiometric bridge.  
**Resistance Range:** 1Ω to 250KΩ.  
**Sample Rate:** 0.8Hz per channel.  
**Digital Resolution:** 24 bits.  
**Measurement Drift:** <25ppm/°C.  
**Measurement Filter:** 0.5, 1, 2, 4, 8, 16, 32 and 64 Seconds.  
**Calibration Curves:** Built-in curves for industry standard sensors plus four user curves with up to 200 entries each. Interpolation is performed using a Cubic Spline.

## Data Logging

Data logging is performed to an internal, 40K byte circular buffer and is time-stamped with a real-time clock. Buffer memory is non-volatile and will retain valid data without AC power. The Model 18 will log a maximum of 1,000 entries where each entry contains eight temperature readings.

## Status Indicators

Alarm LED on the front panel indicates a programmable alarm condition based on input temperature.

## Remote Interfaces

**Ethernet:** Connects to any 10/100 Base-T Ethernet type Local Area Network. Electrically isolated. Connection and activity indicators on rear panel. IP address and sub-net mask are user configurable.

**TCP/IP** user data socket provides remote control and interface to common data acquisition software by using an ASCII command language.

**HTTP** provides built-in web server.

**SMTP** sends e-mail based on user selected alarm conditions.

**Language:** Remote interface language is IEEE SCPI compliant.

**LabView® Drivers** are available.

## General

**Ambient Temperature:** 25°C ± 5°C for specified accuracy.

**Mechanical:** 5.6"W x 2.9"H x 8.8"D.

**Weight:** 3.5 Lbs.

**AC Power Requirement:** 110 or 220VAC, +5% to -10%, 50 to 60Hz, 10 Watts.

**AC Power Switch:** Rear panel.

**Conformity:** European CE certified.

**Calibration:** NIST traceable.

Input Specifications			
	Diode sensors	PTC resistor sensors	NTC resistor sensors
<b>Excitation Mode</b>	DC, Constant-Current	DC Resistance Bridge	DC Resistance Bridge
<b>Ranges</b>	2.50V	2.5KΩ, 25KΩ, 250KΩ	31KΩ 250KΩ
<b>Accuracy:</b> % of Rdg + % of Range	0.005% + 0.001%	0.021% + 0.001%	0.021% + 0.001%
<b>Resolution:</b> % of Range	0.00004%	0.0003%	0.0003%
<b>Excitation Current</b>	10µA DC	1.0mA, 100µA, 10µA	10µA

## Options and Accessories

### Included Accessories

**3018-029** User's Manual.  
**4034-029** Utility software CD.  
**4034-038** Dual sensor input connector/cable assembly.  
**04-0310** Detachable 120VAC Line Cord.  
Certificate of Calibration.

### Optional Accessories

**3012-020** Panel Mount hardware kit.  
**3012-021** Bench top instrument stand.  
**3012-022** Tilt stand and carry handle.  
**4034-033** Shielded sensor connector kit.

## Contact Information

Cryogenic Control Systems, Inc.  
PO Box 7012  
Rancho Santa Fe, CA 92067  
Tel: (858) 756-3900 Fax: (858) 759-3515  
E-mail: [sales@cryocon.com](mailto:sales@cryocon.com) Web: [www.cryocon.com](http://www.cryocon.com)

CalGen® and Cryo-Con® are registered trademarks of Cryogenic Control Systems, Inc. All other product and company names are trademarks or trade names of their respective companies.

©Cryogenic Control Systems, Inc. 2008, M18100108  
Specifications subject to change without notice